

## Full Paper

# Calibration and Implementation of Heat Cycle Requirement of MQ-7 Semiconductor Sensor for Detection of Carbon Monoxide Concentrations

Nisal Kobbekaduwa,\* Pahan Oruthota,\* and W.R. de Mel

Department of Materials and Mechanical Technology, Faculty of Technology, University of Sri Jayewardenepura, Homagama 10200, Sri Lanka

Email correspondence: [kobbekaduwanisal@gmail.com](mailto:kobbekaduwanisal@gmail.com) (N. Kobbekaduwa), [pahanoruthota@sjp.ac.lk](mailto:pahanoruthota@sjp.ac.lk) (P. Oruthota)

Received: 12 August 2021; Revised: 24 September 2021; Accepted: 26 September 2021; Published: 26 September 2021

### Abstract

Carbon monoxide (CO) is a prevalent and widely distributed air pollutant. Its detection and control in residential and industrial environments are essential in order to avoid potentially severe health consequences in people. The aim of this study was to conduct an air quality assessment by measuring CO concentrations using the MQ-7 Semiconductor Sensor. The MQ-7 sensor is a commonly accessible and cost-effective sensor with specific heating needs. The objectives of the study are to provide a method for implementing heater cycle requirements, equipment-less calibration, and the derivation of a formula for measuring CO concentrations in parts per million (ppm). A procedure for calibrating gas sensors is discussed, which involves measuring the sensing resistance and calculating the resistance ratio. The resistance ratio is then used to calculate the target gas concentration in ppm using a formula derived with the aid of Microsoft Excel, such that it represents the original CO characteristic curve provided in the sensor datasheet with greater accuracy. An N-channel MOSFET and Pulse Width Modulated (PWM) voltage were used to get the required heater voltage levels. The methodology developed for calibrating and deriving the equation to determine the target gas concentration can be used for any MQ semiconductor sensor and does not require any special equipment.

**Keywords:** carbon monoxide concentration, heater cycle requirement, indoor air quality, MQ gas sensor, ppm

---

## Introduction

An average adult breathes about 15,000-20,000 liters of air per day [1]. When polluted air is inhaled, the contaminants get into the lungs, enter the bloodstream, and be carried to internal organs, causing adverse health effects. New evidence even suggests that every internal organ of the human body is harmed due to inhalation of

contaminated air [2]. Carbon monoxide (CO) is a prevalent air pollutant that is classified as a class-III toxic gas [3]. Exposure to CO is one of the leading causes of accidental poisoning and is the root cause for a large number of deaths annually all over the world [4]. When considering the adverse health effects of CO exposure, real-time monitoring of the CO concentration in the environment has become significant.

Although there are several ways to monitor the CO concentration level, the metal-oxide-semiconductor (MOS) solution is the most researched CO detection technology. Researchers studied MOS sensors for a lengthy period with a particular focus on CO sensors with high sensitivity, selectivity, absorptivity (of oxygen), stability, reversibility, low power consumption, and low manufacturing costs. The primary purpose of the metal-oxide sensing layer is to determine the amount of CO gas absorbed into the metal-oxide layer by measuring its conductivity. The electrical conductivity changes due to oxygen adsorption on the metal-oxide surface. The reaction between adsorbed oxygen molecules and CO molecules aids in identifying the target gas [5, 6, 7]. The CO concentration can be determined by comparing the conductivity of the oxide layer in the presence of CO to that in the absence of CO.

All sensitive MOS react with CO gas by adsorbing oxygen. However, the variation in electrical conductivity is different in n-type and p-type MOS. When CO gas is exposed to n-type MOSs, the gas is oxidized, and the metal-oxide layers resistance decreases. The most used n-Type MOS for detecting CO are Zinc Oxide (ZnO), Titanium Oxide (TiO<sub>2</sub>), and Tin Oxide (SnO<sub>2</sub>) [8]. This study utilized an MQ-7 (SnO<sub>2</sub>) semiconductor sensor to detect CO concentration in the environment. These semiconductor sensors require calibration in order to eradicate and minimize the factors that cause imprecise measurements [9, 10]. Calibration of gas sensors using calibrating equipment is a more complex and costly process [11]. The paper mainly focuses on developing a simple procedure for equipment-less calibration of the MQ-7 semiconductor sensor and a convenient method of deriving a formula to measure CO concentration in particles

per million. In addition, an approach to address the heater cycle requirement of the sensor.

### MQ-7 Gas Sensor Structure

The MQ-7 gas sensor is composed of a micro Aluminum Oxide ( $Al_2O_3$ ) ceramic tube, a Tin Dioxide ( $SnO_2$ ) sensitive layer, a measuring electrode, and a nickel-chromium (NiCr) heater coil fixed into a crust made of plastic and stainless steel net [12]. Figure 1 illustrates the structure of the sensor. MQ-7 sensor primarily has six pins. Both pins A and B can be connected separately [13]. The specifications of the MQ-7 gas sensor are attached in Appendix-A.

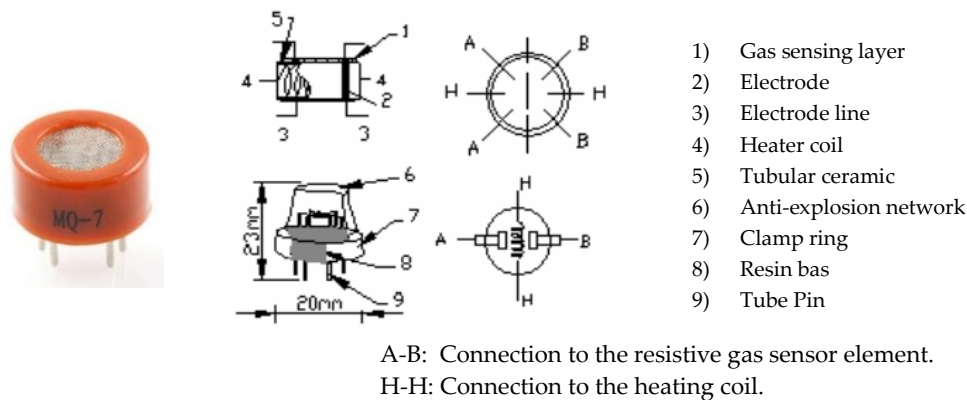

Figure 1. Structure of MQ-7 gas sensor [14]

The primary sensing material of the MQ-7 gas sensor is  $SnO_2$ , which shows higher electrical resistance (lower electrical conductivity) in clean air and lower electrical resistance (higher electrical conductivity) along with high CO concentration. The heater coil provides the necessary working condition for internal sensitive components. Therefore, it is required to maintain a series of heat cycles to detect the CO concentration. As illustrated in Figure 2, the heat cycle consists of a high-temperature state and a low-temperature state. Applying 1.4 V across the heater coil for 90 seconds results in a low-temperature state in which the CO concentration is measured. Also, 5 V must be applied across the heater coil for 60 seconds to achieve the high-temperature state, in which other gases absorbed during the low-

temperature state are cleaned. Therefore, it is crucial to continuously maintain the heat cycle to get an accurate measurement of CO concentration. The sensor must undergo 48 hours of burn-in (run heat cycle) to obtain stabilized readings [15].

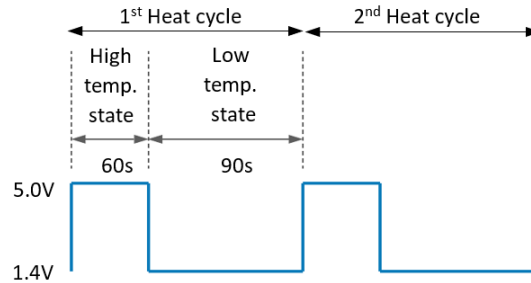

Figure 2. Heat cycle with high and low-temperature states

### MQ-7 Test Circuit

Figure 3 illustrates a simple test circuit for the MQ-7 gas sensor, which requires two voltage inputs: heater voltage ( $V_H$ ) and circuit voltage ( $V_C$ ). Heater voltage ( $V_H$ ) supplies voltage for the heater coil of the sensor. The circuit voltage ( $V_C$ ) drives the gas sensor circuit, which comprises the sensing element and the load resistor ( $R_L$ ).  $V_{RL}$  is the voltage across the load resistor, which is in series with the sensing element resistance ( $R_S$ ).

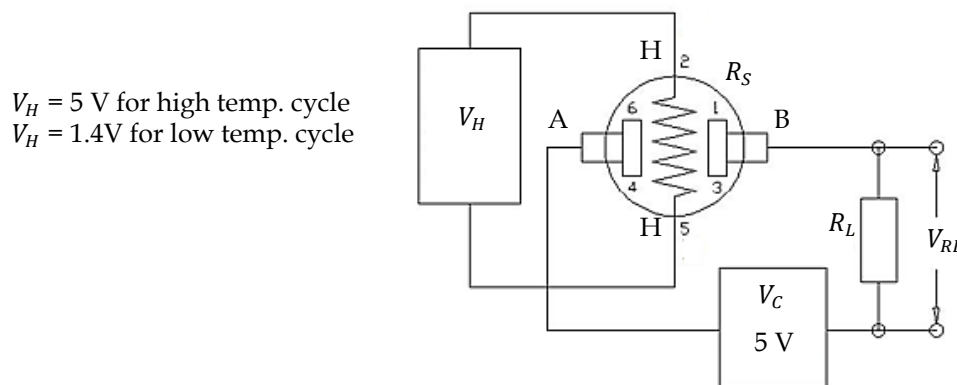

Figure 3. MQ-7 Test circuit [14]

### Materials and Methods

This section describes the implementation of the heater cycle requirement, calibration process, and formula derivation to detect CO concentration in parts per million (ppm).

### *Implementation of Heater Cycle Requirement*

The heater cycle of the sensor was implemented based on the Pulse Width Modulation (PWM) technique of an Arduino microcontroller (Mega 2560). PWM is a method for obtaining analog results using digital means [16]. Digital control is used to create a square signal, which is a signal that switches between on and off (High and Low). This on-off pattern can simulate voltages between the board's full  $V_{CC}$  (Voltage Common Collector) and off by changing the portion of the time signal spends on (High) versus the signal's time off (Low). The duty cycle is the percentage of time the signal was high (on) during a period, and a period is the amount of time required for a signal to complete an on-and-off cycle. Changing the duty cycle results in varying analog values. When a device is powered by PWM, it behaves similarly to the average of the pulses [17, 18]. The average voltage level might be steady or dynamic. However, if the on-off pattern is repeated fast enough, the signal will appear to be a steady voltage between 0 and  $V_{CC}$ . Assume that the high-level voltage on a PWM-driven device is 5 V and the low-level voltage is 0 V. If the pulse is driven at 50% duty cycle, then the average voltage can be calculated by multiplying the duty cycle by the pulses high level, which is 2.5 V.

To address the sensor's heater cycle requirement, the duty cycles of the PWM signal were set to be equivalent to 5 V and 1.4 V. The program codes used to generate the PWM signal are included in Appendix-D. Even though the voltages can be generated, the maximum current on a single input/output pin of an Arduino Mega 2560 is limited to 40 mA [19]. But the MQ-7 sensor with a heater consumption of 350 mW [14] requires a much higher current to drive the heater cycle, which is typically beyond the limits of the Arduino Mega 2560 specifications. As the solution, a Metal-Oxide-Semiconductor Field-Effect Transistor (MOSFET) was used to handle the high current required for the heater coil. A MOSFET was essentially used by considering its responsiveness and high current capability compared to bipolar junction transistors (BJT) [20]. As illustrated in Figure 4, an N-channel MOSFET (IRF 2807) was used in the

experimental setup to implement the required PWM signal to drive the sensor's heater coil.

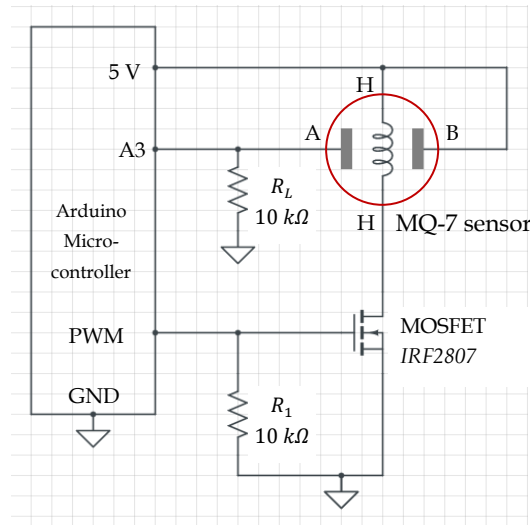

Figure 4. Implementation of heater cycle by using an Arduino microcontroller

### Calibration of MQ-7 Gas Sensor

The Sensitivity Characteristics of the MQ-7 Sensor are shown in Figure 5 [14]. The graph can be used to determine the CO concentration in ppm with respect to the resistance ratio ( $\frac{R_S}{R_0}$ ) of the sensor, the same principle is used for the calibration process. This experiment was conducted under the assumption that the ambient air is clean. Please note that the graph has logarithmic scales on both x and y axes.

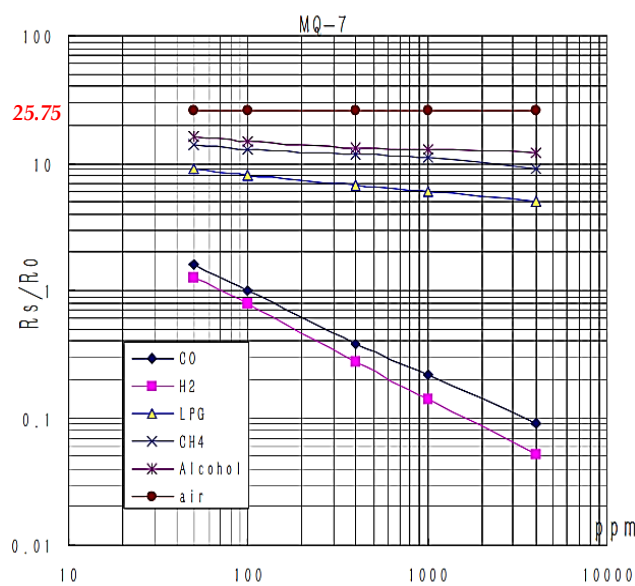

Figure 5. Sensitivity characteristics of the MQ-7 sensor  
 $R_0$  – Gas sensor resistance in clean air

$R_S$  – Gas sensor resistance at different CO concentration

According to the graph, it is clear that the resistance ratio  $\left(\frac{R_S}{R_O}\right)$  of the MQ-7 sensor in clean air is approximately 25.75 (refer to the characteristic curve corresponding to air). Therefore, the following expression can be written for the resistance ratio in clean air.

$$\frac{R_S}{R_O} = 25.75 \quad (\text{Equation 1})$$

If the value of  $R_S$  in Equation 1 is known, the remaining term  $R_O$  can be determined since the resistance ratio is already known as 25.75. Therefore, the target of the calibration process is to find  $R_O$  in ambient air conditions (clean air).

Considering Equation 1, it is required to find the value of  $R_S$  to calculate  $R_O$ . The value of  $R_S$  in clean air needs to be determined experimental procedures as described in the following sections. The voltage divider rule can be used to obtain the following expression for the MQ-7 gas sensor test circuit shown in Figure 3.

$$V_{RL} = V_C \times \left(\frac{R_L}{R_S + R_L}\right)$$

The sensor resistance  $R_S$  can be calculated as

$$R_S = \left(\frac{V_C}{V_{RL}} - 1\right) \times R_L \quad (\text{Equation 2})$$

The only unknown parameter in Equation 2 is  $V_{RL}$ . It can be experimentally determined as described below.

For the experimental setup, a 10 k $\Omega$  resistor was used as the load resistor ( $R_L$ ) and voltage ( $V_{RL}$ ) across the load resistor was measured using the Arduino microcontroller. Figure 6 illustrates the experimental setup used to determine CO concentration.

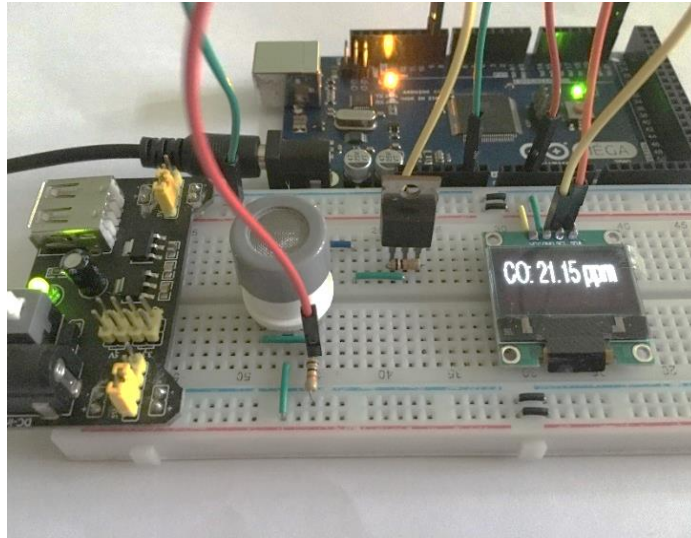

**Figure 6.** Experimental setup for the CO concentration

The value of  $R_0$  can be directly obtained from the experimental setup by implementing Equation 2 and Equation 1 in the microcontroller unit. Program codes corresponding to the calibration process are included in Appendix C. The test was done in ambient air conditions for three trials, and each trial had twenty readings for  $R_0$ , taken each in between 150 seconds (the period of the heat cycle). The readings were tabulated as shown in Table B1 in Appendix-B. Once the test was completed, the average value for  $R_0$  was determined as  $2.12 \text{ k}\Omega$ . Minor changes in the data points were observed during the trials due to the effects of temperature and humidity. The impact of these two parameters was not taken into account.

### ***Results and Discussion Section***

#### ***Developing a Formula to Determine the CO Concentration***

Once the calibration process is completed, CO concentration in any condition can be determined using the CO characteristic curve provided in the sensor datasheet. However, using manual means to determine the gas concentration corresponding to the resistance ratio using merely the graph is a complicated and time-consuming process. Hence utilizing a computer application to derive the characteristic curve equation simplifies the process and produces more accurate results. In order to



develop an equation, it is essential to extract the data points of the resistance ratio ( $\frac{R_s}{R_o}$ ) and the corresponding CO concentration values. Table 1 was prepared using the extracted data points.

**Table 1.** Data Points extracted from the CO characteristic curve using WebPlotDigitizer [21]

CO concentration [ppm]	Resistance ratio ( $\frac{R_s}{R_o}$ )
49.43	1.58
97.87	1.00
393.68	0.38
995.71	0.22
4005.08	0.09

As shown in Figure 7, a new graph was plotted using the data points extracted from the CO characteristic curve. As the next step, the best fit curve and its equation were found using the trendline option of Microsoft Excel [22], such that it represents the original CO characteristic curve with greater accuracy.

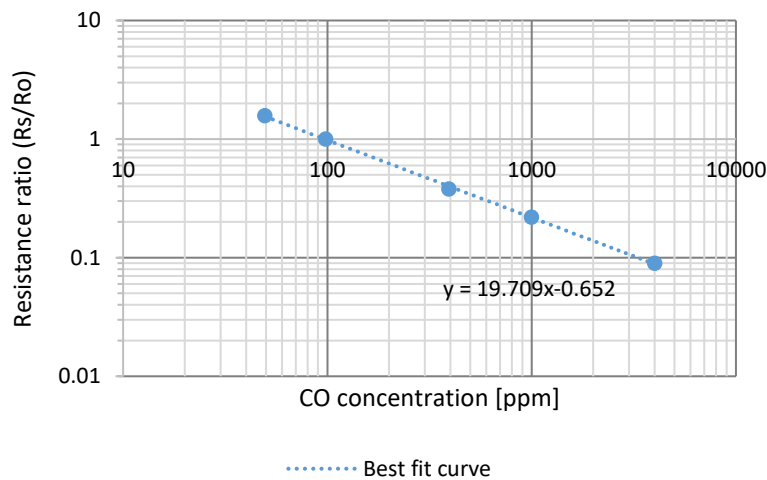

**Figure 7.** Best fit CO concentration characteristic curve in clean air

The equation of the best fit curve for CO was found as,

$$y = 19.709 x^{-0.652} \quad (\text{Equation 3})$$

$x$  – CO concentration in ppm

$y$  – Resistance ratio  $\left(\frac{R_S}{R_O}\right)$

Equation 3 can be rearranged to find the CO concentration in any condition if the resistance ratio  $\left(\frac{R_S}{R_O}\right)$  is known. Hence, the required formula can be expressed as,

$$\text{CO concentration [ppm]} = \left[ \frac{\left(\frac{R_S}{R_O}\right)}{19.709} \right]^{\left(\frac{-1}{0.652}\right)} \quad (\text{Equation 4})$$

**Steps Implemented in the microcontroller to determine CO concentration in ppm**

*Step 1:* Find the gas sensor resistance ( $R_S$ ) in the target environment using the experimental setup.

*Step 2:* Compute the resistance ratio  $\left(\frac{R_S}{R_O}\right)$  for that particular condition by taking  $R_O = 2.12 \Omega$  (i.e., the gas sensor resistance in clean air (ambient air), determined in the calibration process).

*Step 3:* Substitute the resistance ratio in Equation 4 to calculate the CO concentration in that particular condition.

**Conclusion**

Calibration of MQ-7 gas sensors with the use of lab equipment is a complex process. A simple procedure for calibrating the sensor was developed. It involves determining the sensor resistance in ambient air ( $R_O$ ), which was determined to be  $2.12 K\Omega$ . CO concentrations were measured relative to the sensor resistance in ambient air conditions ( $R_O$ ). The formula for determining CO concentration was derived as

$$\left[ \text{CO (ppm)} = \left[ \frac{\left(\frac{R_S}{R_O}\right)}{19.709} \right]^{\left(\frac{-1}{0.652}\right)} \right] \text{ using the CO characteristic curve provided in the}$$

datasheet. A simple circuit was designed utilizing an N-channel MOSFET (IRF 2807) to implement the required PWM signal to address the heater cycle requirement of the

sensor. Since the effects of temperature and humidity were not considered, an averaging method was executed to compensate for minor deviations in data points. Other calibration procedures involving temperature and humidity compensations may result in more accurate readings at the expense of increased complexity. Even though the study focuses only on the MQ-7 sensor, this developed method of calibration and formula derivation can be used with any type of MQ sensor (MQ-6, MQ131, etc.).

### **Conflict of Interest**

The authors declare no conflict of interest.

### **References**

- [1] D. Wendt, M. Kutter, IAQ &ndash; Indoor Air Quality The importance for our health, <https://www.envirotech-online.com/article/air-monitoring/6/eco-physics-ag/iaq-ndash-indoor-air-quality-the-importance-for-our-health/198>, accessed: August, **2021**.
- [2] D.E. Schraufnagel, J.R. Balmes, C.T Cowl, S. Matteis, S.H. Jung, K. Mortimer, R. Perez-Padilla, M.B. Rice, H. Riojas-Rodriguez, A. Sood, G.D. Thurston, T To, A. Vanker, D.J. Wuebbles, Air Pollution and Noncommunicable Diseases: A Review by the Forum of International Respiratory Societies' Environmental Committee, Part 2: Air Pollution and Organ Systems. **2021**, 155(2),417-426.
- [3] National Research Council. The ongoing challenge of managing carbon monoxide pollution in Fairbanks, Alaska. Washington, D.C.: National Academy Press; **2002**, 6p.
- [4] C. Mattiuzzi, G. Lippi. Worldwide epidemiology of carbon monoxide poisoning, *Hum Exp Toxicol.* **2020**, 39(4), 387-392p.
- [5] G. Korotcenkov, Gas response control through structural and chemical modification of metal oxide films: State of the art and approaches. *Sens. Actuator B Chem.* **2005**, 107(1), 209–232p.
- [6] N. Yamazoe, G. Sakai, K. Shimano, Oxide semiconductor gas sensors, *Catalysis Surveys from Asia.* **2003**, 7, 63–75p.
- [7] N. Yamazoe, Toward innovations of gas sensor technology, *Sensors and Actuators B: Chemical.* **2005**, 108(1), 2–14p.
- [8] T. Nandy, R. Coutu, C. Ababei, A. Roland, Carbon Monoxide Sensing Technologies for Next-Generation Cyber-Physical Systems, *Sensors.* **2018**, 18(10), 3443p.
- [9] S. Sheng-wen, J. Chen, B. Chen, H. Huang, Z. Ye, M. Cheng, C. Liu. A field calibration method based on forward transport coefficient for UHF partial discharge detection sensors in GIS, *High Voltage Engineering and Application (ICHVE). IEEE.* **2016**, 1-4p.

- [10] D. Fan, J. Gong, B. Ghaemmaghami, A. Zhang, J. Lach, D. B. Peden. Characterizing and Calibrating Low-Cost Wearable Ozone Sensors in Dynamic Environments, **2017**.
- [11] K. Senthil Babu, C. Nagaraja. Calibration of MQ-7 and Detection of Hazardous Carbon Mono-oxide Concentration in Test Canister, *International Journal of Advance Research, Ideas and Innovations in Technology*, **2018**, 4(1), 18-24p.
- [12] A.R. Jaladi, K. Khithani, P. Pawar, K. Malvi, G. Sahoo. Environmental monitoring using wireless sensor networks (WSN) based on IOT. *Int. Res. J. Eng. Technol.*, **2017**, 4(1), 1371-1378p.
- [13] R. Rumantri, M. Y. N. Khakim, I. Iskandar. Design and Characterization of Low-Cost Sensors for Air Quality Monitoring System, *Jurnal Pendidikan IPA Indonesia*, **2018**, 7(3), 347-354p.
- [14] Hanwei Electronics CO - MQ7 Sensor Datasheet pdf, <https://datasheetspdf.com/pdf/694312/Hanwei/MQ7/1>, accessed: September, **2021**. [Online].
- [15] N.M. Sakayo, J.N. Mutuku, J.M. Ngaruiya, Design and Calibration of a Microcontroller Based MQ-4 Gas Sensor for Domestic Cooking Gas System, *International Journal of Applied Physics*, **2019**, 6(2), 31-40p.
- [16] A. Shankar, A. Lokeshwari, B. Manohar, S. Pranavi, Implementation of Simple PWM/PPM Generator for Microcontroller Using Verilog, *International Journal of Advanced Research in Engineering and Technology (IJARET)*, **2021**, 12(3), 97-102p.
- [17] S.F. Barrett, D.J. Pack, *Microcontrollers fundamentals for engineers and scientists*, Morgan and Claypool Publishers, **2006**, 51-64p.
- [18] J.A. Mohammed, Pulse Width Modulation for DC Motor Control Based on LM324, *Eng & Tech Journal*. **2013**, 31(A), 1882-1896p.
- [19] Arduino Mega 2560 Datasheet, <http://eprints.polsri.ac.id/4598/8/File%20VIII%20%28Lampiran%29.pdf>, accessed: September, **2021**. [Online].
- [20] W. Liu, A. Badel, F. Formosa, Q. Zhu, Comparative Case Study on the Self-Powered Synchronous Switching Harvesting Circuits With BJT or MOSFET Switches, *IEEE Transactions on Power Electronics*, **2018**, 33(11), 9506-9519p.
- [21] D. Drevon, S.R. Fursa, A.L. Malcolm. Intercoder reliability and validity of WebPlotDigitizer in extracting graphed data. *Behavior modification*, **2017**, 41(2), 323-339p.
- [22] M. Middleton. Better exponential curve fitting using excel, *J Power Sources*, **2010**, 92, 120-123p.

Appendix – A

MQ-7 Gas Sensor Specifications:

A. Standard work condition

Symbol	Parameter name	Technical condition	Remark
Vc	circuit voltage	5V ± 0.1	Ac or Dc
VH (H)	Heating voltage (high)	5V ± 0.1	Ac or Dc
VH (L)	Heating voltage (low)	1.4V ± 0.1	Ac or Dc
RL	Load resistance	Can adjust	
RH	Heating resistance	33 Ω ± 5%	Room temperature
TH (H)	Heating time (high)	60 ± 1 seconds	
TH (L)	Heating time (low)	90 ± 1 seconds	
PH	Heating consumption	About 350mW	

b. Environment conditions

Symbol	Parameters	Technical conditions	Remark
Tao	Using temperature	-20°C-50°C	
Tas	Storage temperature	-20°C-50°C	Advice using scope
RH	Relative humidity	Less than 95%RH	
O <sub>2</sub>	Oxygen concentration	21%(stand condition) the oxygen concentration can affect the sensitivity characteristic	Minimum value is over 2%

c. Sensitivity characteristic

symbol	Parameters	Technical parameters	Remark
Rs	Surface resistance Of sensitive body	2-20k	In 100ppm Carbon Monoxide
a (300/100ppm)	Concentration slope rate	Less than 0.5	Rs (300ppm)/Rs(100ppm)
Standard working condition	Temperature -20°C ± 2°C relative humidity 65% ± 5% RL:10K Ω ± 5% Vc:5V ± 0.1V VH:5V ± 0.1V VH:1.4V ± 0.1V		
Preheat time	No less than 48 hours	Detecting range: 20ppm-2000ppm carbon monoxide	

## Appendix – B

**Table B 1.** Gas sensor resistance in clean air ( $R_0$ ) for the test

Reading No.	Ro – Gas sensor resistance in clean air (Ohm)		
	Trial 1	Trial 2	Trial 3
1	2.14	2.16	2.21
2	2.16	2.21	2.19
3	2.21	2.19	1.79
4	2.19	1.79	1.53
5	1.79	1.53	2.03
6	1.53	2.03	2.16
7	2.03	2.16	2.17
8	2.16	2.17	2.17
9	2.17	2.17	2.14
10	2.17	2.14	2.14
11	2.14	2.14	2.17
12	2.14	2.17	2.17
13	2.17	2.17	2.19
14	2.17	2.19	2.19
15	2.19	2.19	2.16
16	2.19	2.16	2.21
17	2.16	2.21	2.21
18	2.21	2.21	2.21
19	2.21	2.21	2.23
20	2.21	2.23	2.14
<b>Average value (<math>R_0</math>):</b>	<b>2.12</b>	<b>2.12</b>	<b>2.12</b>

## Appendix – C

### Program Code for the Calibration Process of the MQ-7 Gas Sensor

```

int CO_sensorPin = A2;    // select the input pin for the CO sensor
int pwmpin = 9;          // PWM signal to the MOSFET

void setup() {
    Serial.begin(9600);    //Baud rate
    pinMode(CO_sensorPin, INPUT); // To get input from the sensor
    pinMode(pwmpin, OUTPUT); // To give the pluse width modulation to
the n channel MOSFET
}
void loop() {
    float CO_VRL;          //Define variable for sensor voltage
    float CO_RS;          //Define variable for sensor resistance
    float CO_R0;          //Define variable for R0
    float CO_sensorRead=0.0; //Define variable for analog readings
    float CO_RL=10;       //Load Resistance (Units are Kilo Ohms)
    float CO_VC=5.0;      //Supply DC voltage

    //****MQ-7****
    analogWrite(pwmpin, 255); // turn the heater to 5V
    delay(60000);             // heat for 60 second
    analogWrite(pwmpin, 72); // turn the heater to 1.4V
    delay(90000);            // wait for 90 seconds | Read values at heater voltage
1.4V

    // read the value from the sensor and calculations:
    CO_sensorRead = analogRead(CO_sensorPin); //Read analog values of
sensor

    CO_VRL = CO_sensorRead*(CO_VC/1023.0); //Convert Sensor analog signal to
voltage

    CO_RS = ((CO_VC/CO_VRL)-1) * CO_RL; //Calculate RS (sensor resistance) in
fresh air

    CO_R0 = CO_RS/25.75;          //Calculate R0 I got 25.75 from the
graph in the data sheet

    Serial.print("Sensor resistance in ambient air R0 ");
    Serial.print(CO_R0);
    delay(1000); //Wait 1 second
}

```

## Appendix – D

### Program Code for Measuring the CO Concentration in Any Condition

```

int sensorPin = A2;          // select the input pin for the CO sensor
int pwmPin = 9;             // PWM signal for the MOSFET
float R0 = 2.12;            // R0 value measured and calculated in the
                             calibration step previously

void setup() {
  Serial.begin(9600);        //Baud rate
  pinMode(sensorPin, INPUT); // To get input from the sensor
  pinMode(pwmPin, OUTPUT);   // To give the pluse width modulation to the n
channel MOSFET
}
void loop() {

  float sensorRead=0.0;      //Define variable for analog readings
  float RS;                  //Define variable for sensor resistance
  float ratio;               //Define variable for resistance ratio
  float VRL;                 //Define variable for sensor voltage
  float VC=5.0;              //Supply Voltage
  float RL=10;               //Load Resistance(Units are Kilo Ohms)
  double COppm;              //Carbon monoxide in Particles per Million

  // **** Heater Cycle ****
  Serial.println("Heating sensor at high voltage for 60 seconds");
  analogWrite(pwmPin, 255);   // turn the heater to 5V
  delay(60000);               // heat for 60 second
  Serial.println("Heating sensor at low voltage for 90 seconds");
  analogWrite(pwmPin, 72);    // turn the heater to 1.4V
  delay(90000);               // wait for 90 seconds | Read values at heater
voltage 1.4V

  // read the value from the sensor and calculations
  sensorRead = analogRead(sensorPin); //Read analog values of sensor

  VRL = sensorRead*(VC/1023.0);      //Convert Sensor analog signal to voltage

  RS = ((VC/VRL)-1) * RL;            //Calculate RS in fresh air

  ratio = RS/R0;                     // Get resistance ratio

  COppm = pow((19.709/ratio),(1/0.652)); // Got these values through the
trendline method using excel sheet | The intial equation of the trend line
was y=19.709x^(-0.652)

  Serial.print("Carbon monoxide = ");
  Serial.print(COppm);               // FINAL Carbon Monoxide Concentration in
PPM
  Serial.println(" ppm");
  delay(1000);
}

```